

Read before  
using  
equipment.



w3000 Guardian Hub

# Quick Start Guide



# Welcome to safer swimming.

Thank you for your dedication to keeping your swimmers safer.

Your WAVE system has arrived preconfigured for your facility.

Please read this Quick Start Guide completely prior to setting up your system.

**For more detailed information and before using the system we strongly recommend that you read the online New User Guide** available at [saferswimming.com/user-resources](https://saferswimming.com/user-resources) (see below).

Please save all packing materials for storage or to ship equipment if needed.

If you have any questions or need any assistance please contact us at [saferswimming.com](https://saferswimming.com)



To read detailed NEW USER GUIDE visit  
[saferswimming.com/user-resources](https://saferswimming.com/user-resources)

Required Password:



**IMPORTANT! WAVE SYSTEM products are designed to supplement and NEVER replace responsible human supervision of swimmers. Only another human being can investigate, intervene and rescue a potential drowning victim if necessary. NEVER LET ANYONE SWIM ALONE OR UNATTENDED REGARDLESS OF AGE OF SWIMMING ABILITY LEVEL OR EXPERIENCE.**

# WAVE System Equipment

Depending on your facility's configuration some equipment may or may not be included. After unpacking please inspect the enclosed packing slip to confirm that all equipment listed is included. If anything is missing please contact us immediately at [support@saferwithWAVE.com](mailto:support@saferwithWAVE.com).

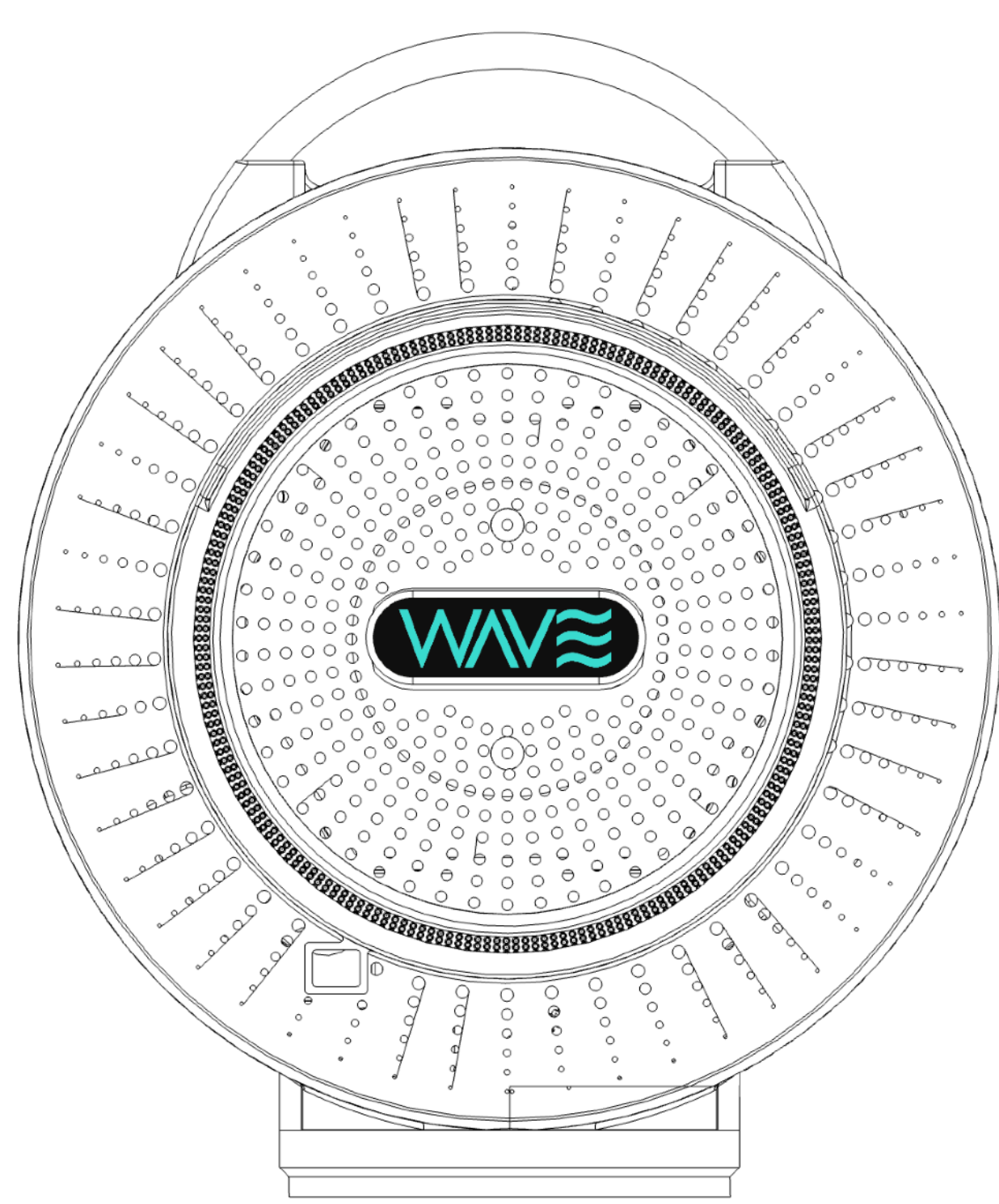

w3000  
Guardian Hub

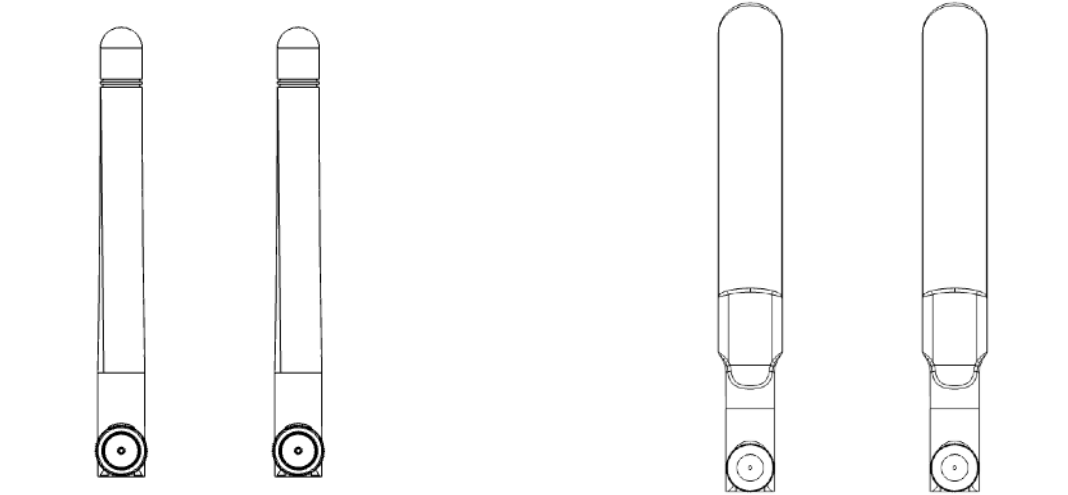

2 x Wi-Fi  
Antennas

2 x Cellular  
Antennas

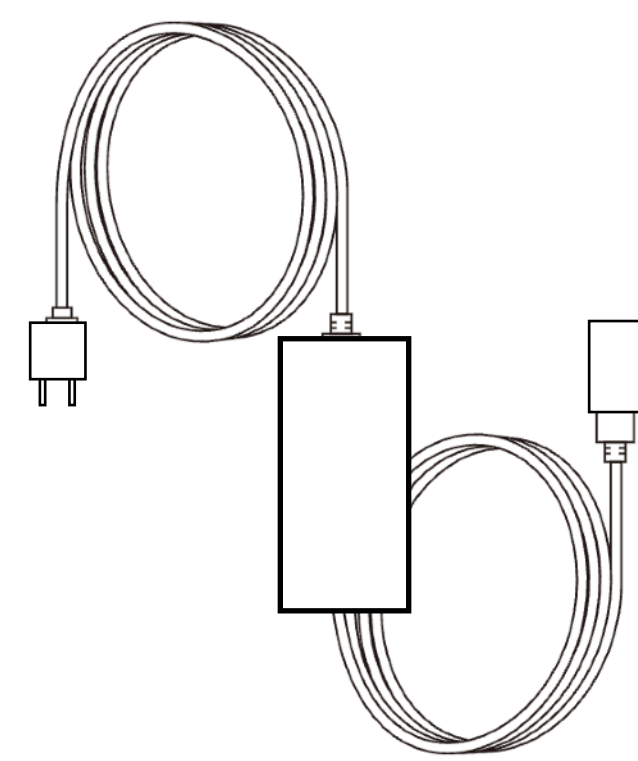

AC Adapter/  
Charger

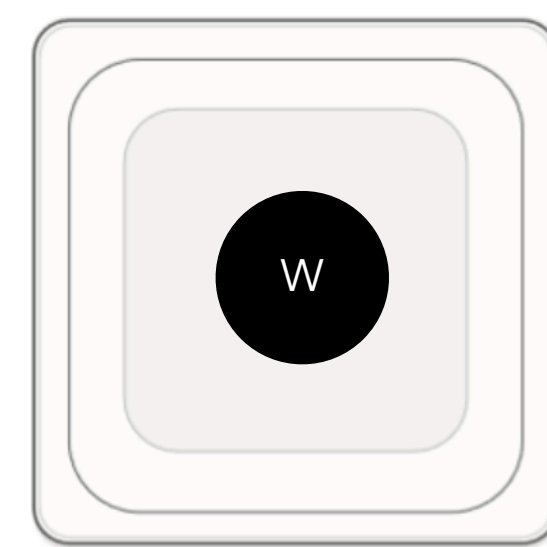

Indoor  
Extended  
Monitor

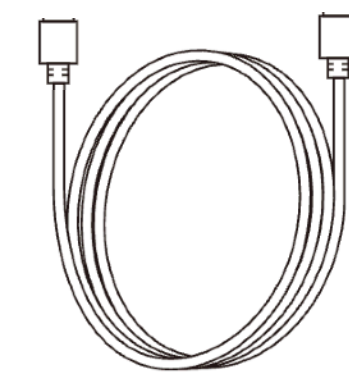

Ethernet  
Cable

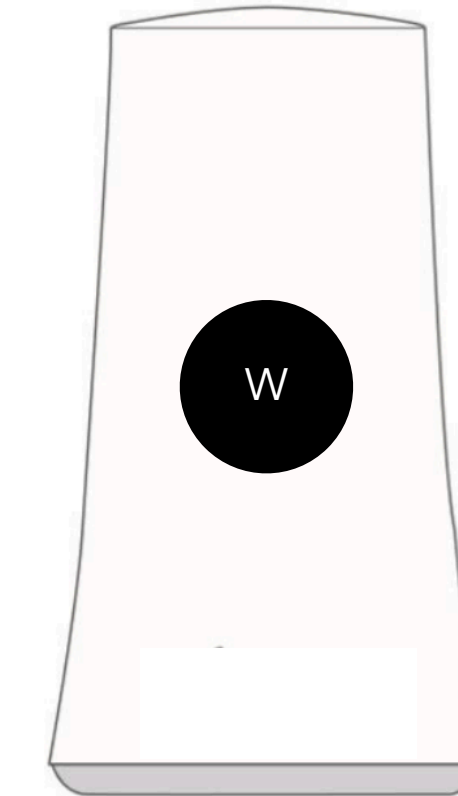

Outdoor  
Monitor

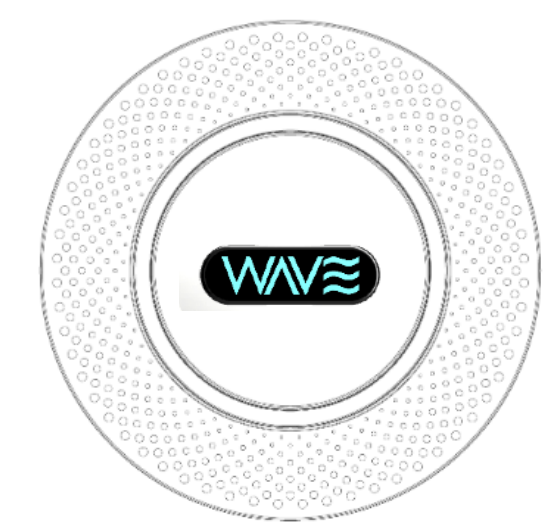

Indoor Monitor  
+ USB cable and AC Adapter



Control Tablet  
+ USB cable & AC Adapter

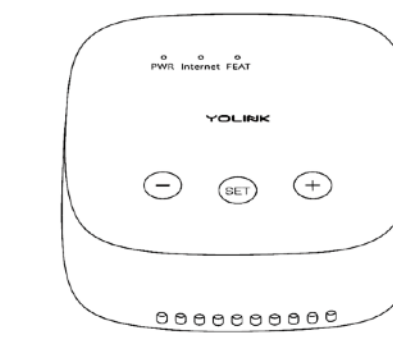

Remote Speaker  
+ USB cable & AC Adapter

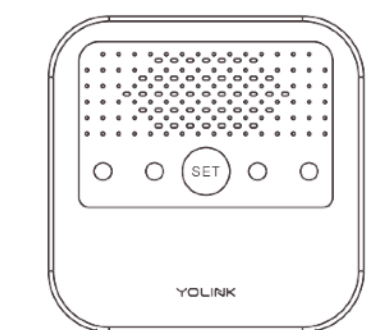

Remote Siren  
+ USB cable & AC Adapter

## Staff Wearables

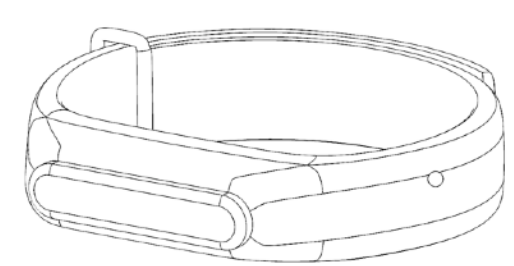

Staff Bracelets

+

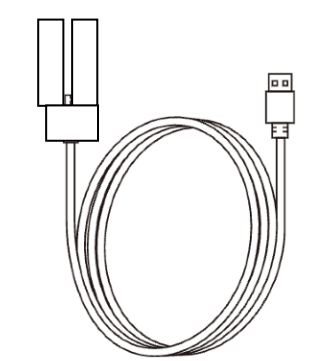

Charging  
Clip & cable

+

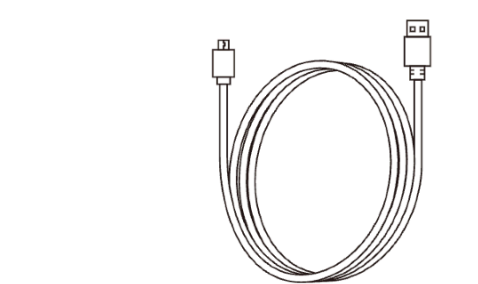
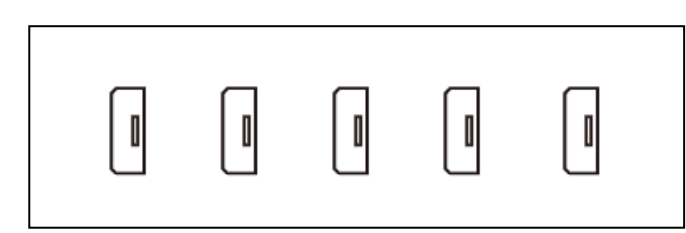

Multi-USB Port Charger  
+ USB cable  
+ AC Adapter

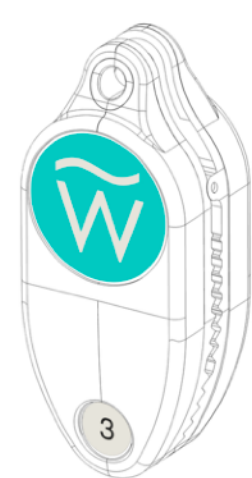

Lifeguard Tags

## Swimmer Wearables

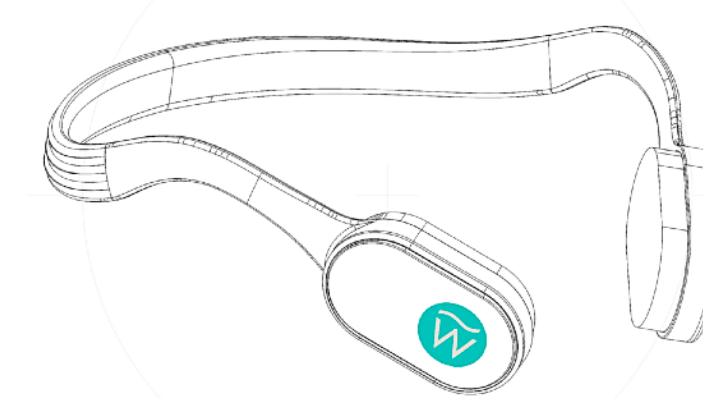

Tracker Headsets

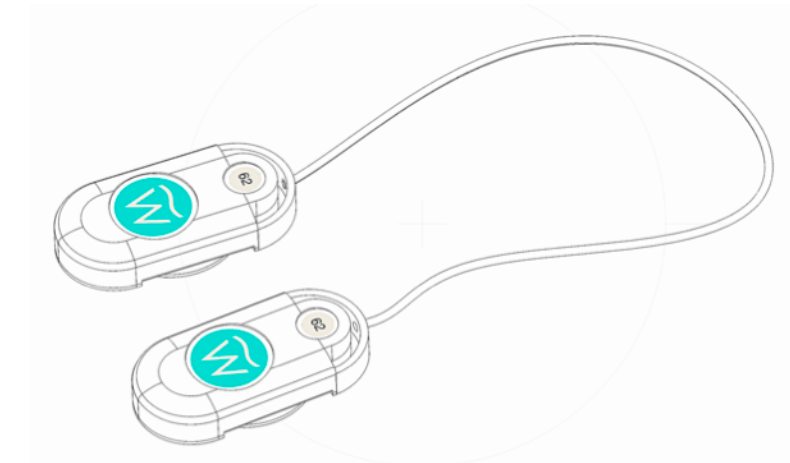

Goggle Clips

[ Images not to scale ]

## Determining where to position equipment:

It is strongly recommended to position equipment temporarily (using extra hands, ladders, etc) and testing prior to permanent installation. See page 5 of this guide.

### Mounting the w3000 Hub.

Depending on your configuration the **Hub** is to be mounted to a wall or pole using the included VESA mount, or on a tripod for temporary or portable use. For fixed use it is recommended to mount the Hub near a GFCI-protected AC outlet.

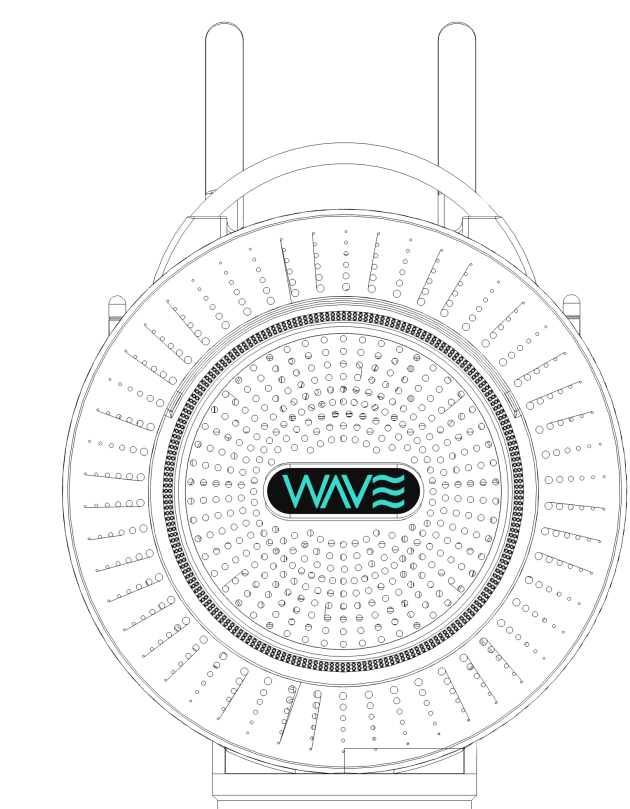

w3000  
Guardian Hub

### Mounting the Monitor.

Depending on your configuration the included **Monitor**\* is to be mounted to a wall or pole and is connected to the Hub using the included Ethernet cable. For temporary or portable use the Monitor may be mounted to a tripod. **It is critical for system accuracy to position the Monitor with an unobstructed view of the entire area where wearables will be used.**

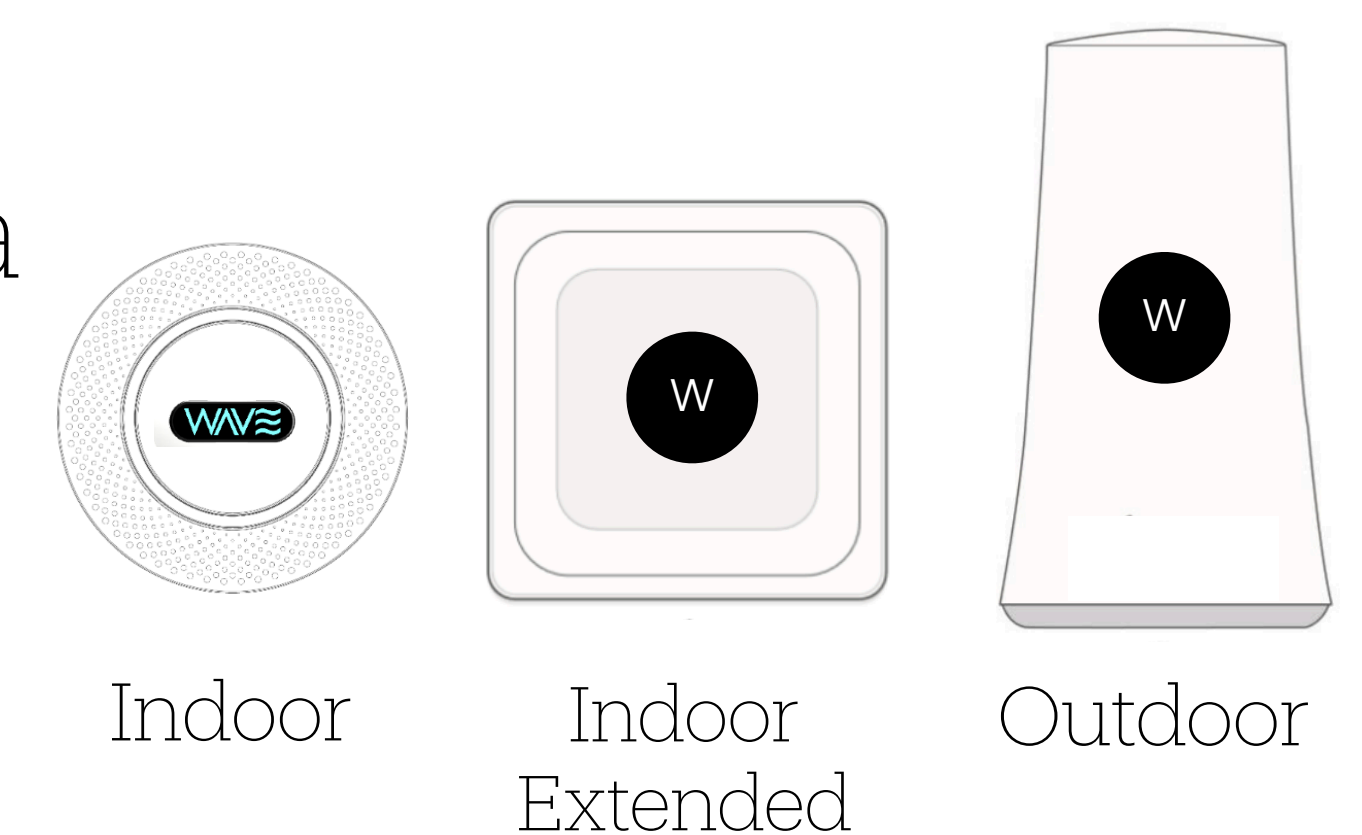

Indoor

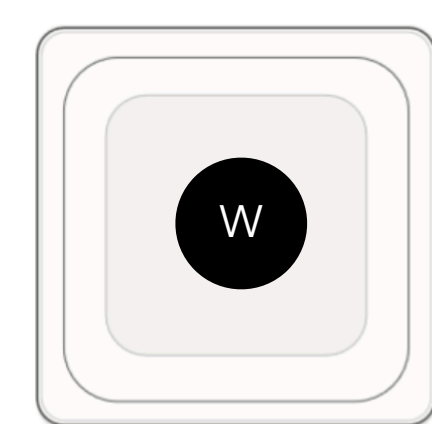

Indoor  
Extended

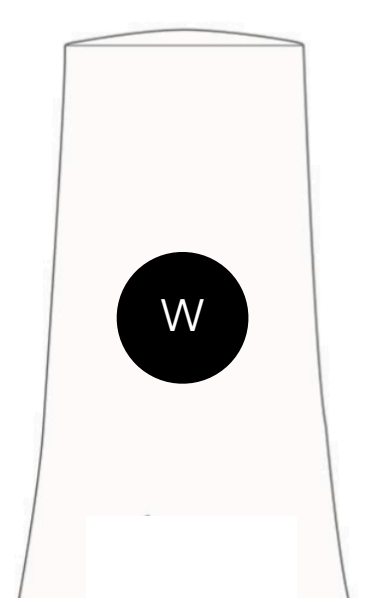

Outdoor

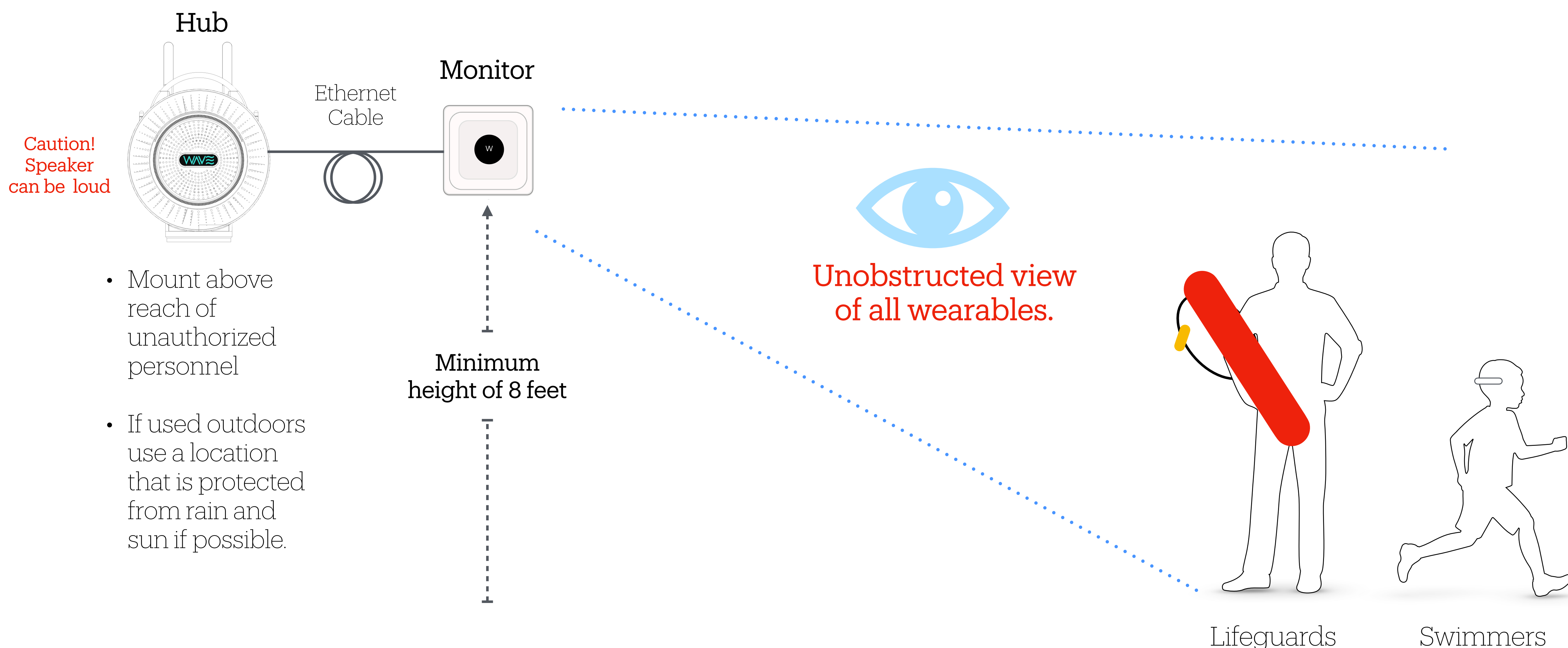

\* Depending on your system configuration multiple monitors may be used.

## ■ Connecting and powering your system.

(1) Securely attach included Wi-Fi and Cellular Antennas (2) Attach Power-In Connector from AC Adapter (3) Attach Ethernet cable from Monitor, and (4) Ethernet cable from facility if being used (5) Connect to adapter to AC wall outlet (6) Power on Hub only after all connections are made.

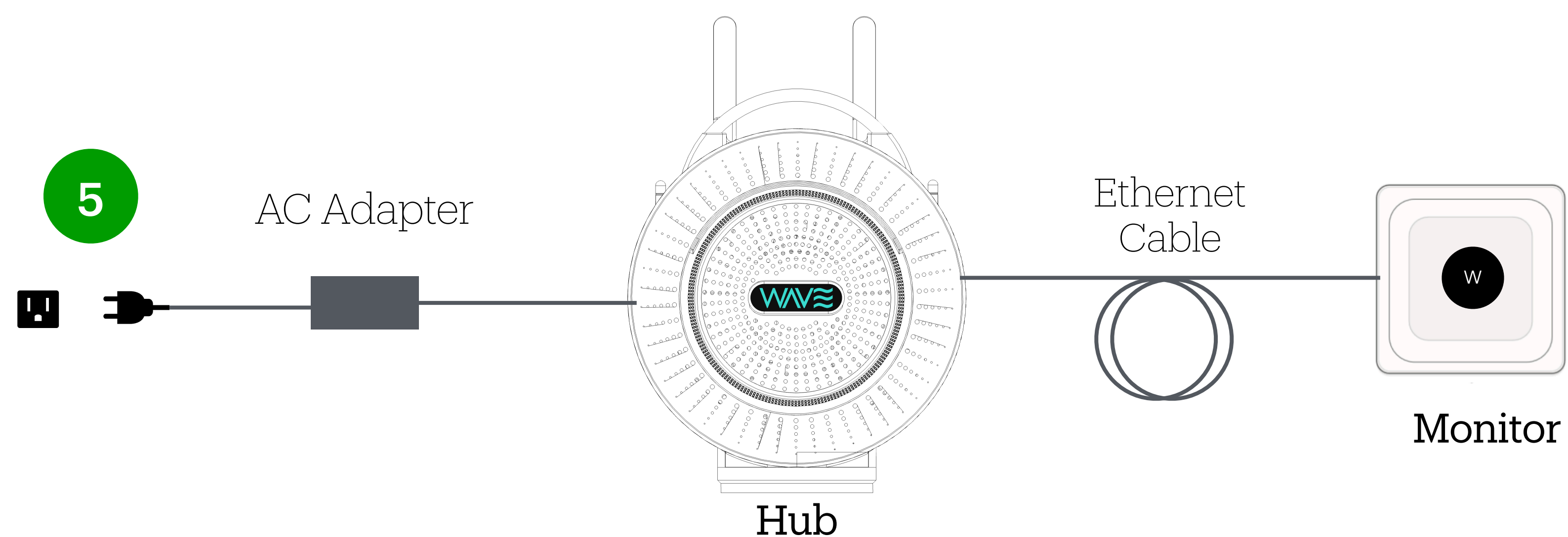
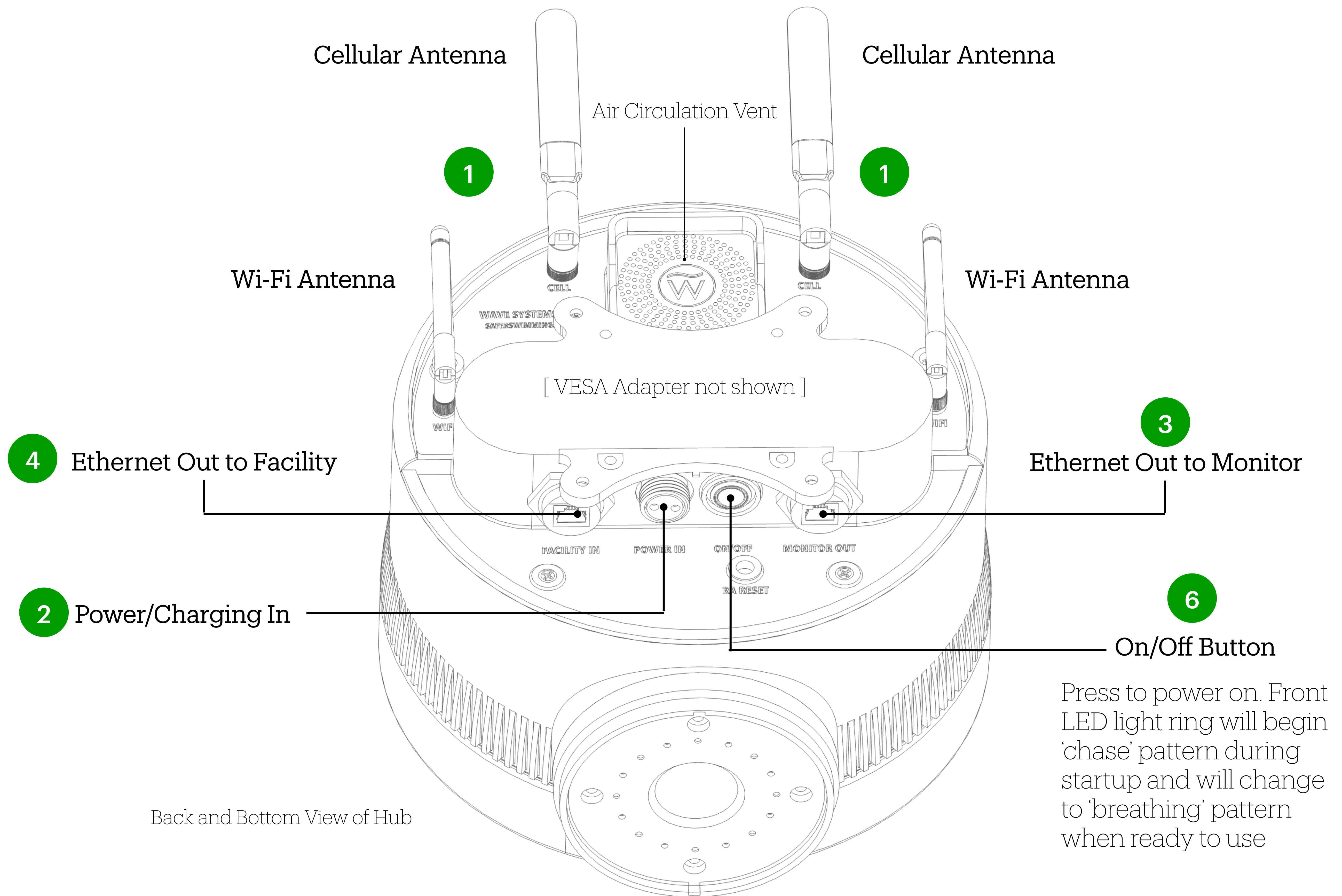

# Setting Up Remote Alert Units.

## Remote Speaker

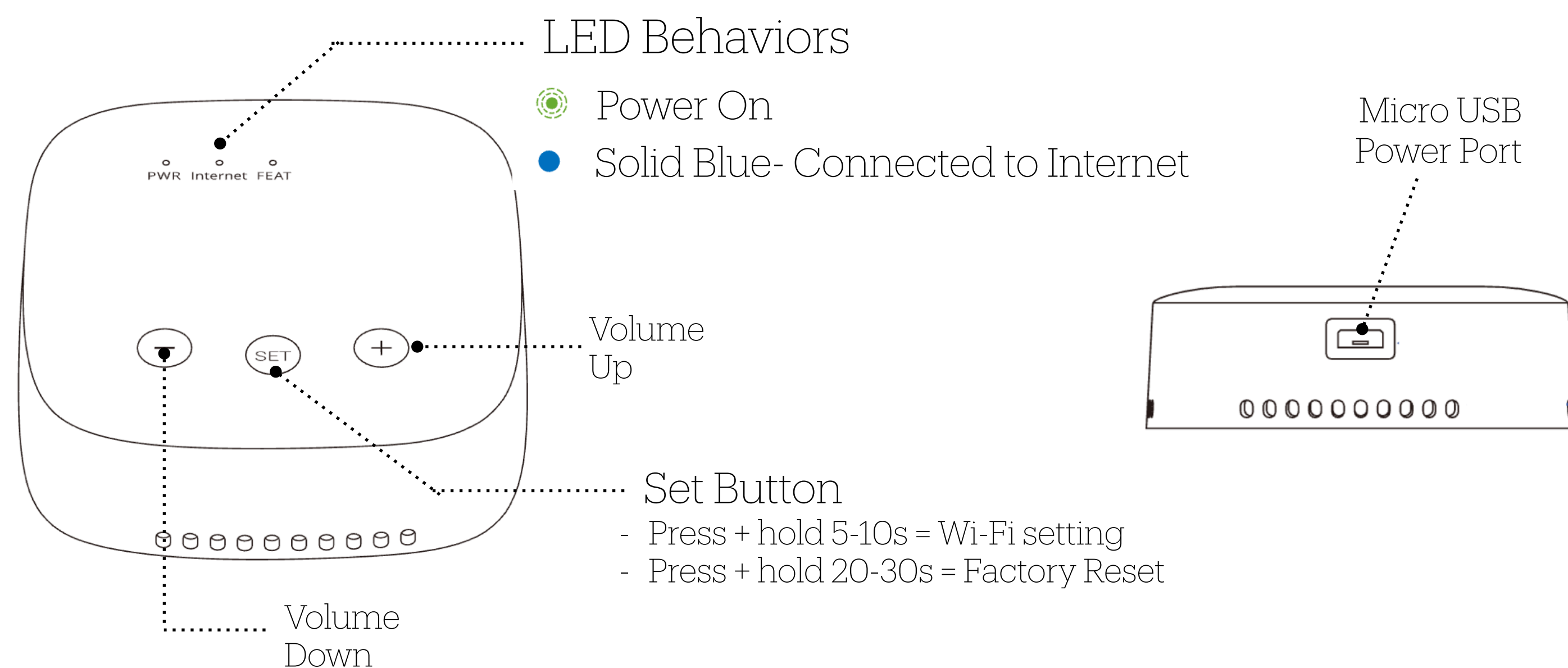

## Remote Siren

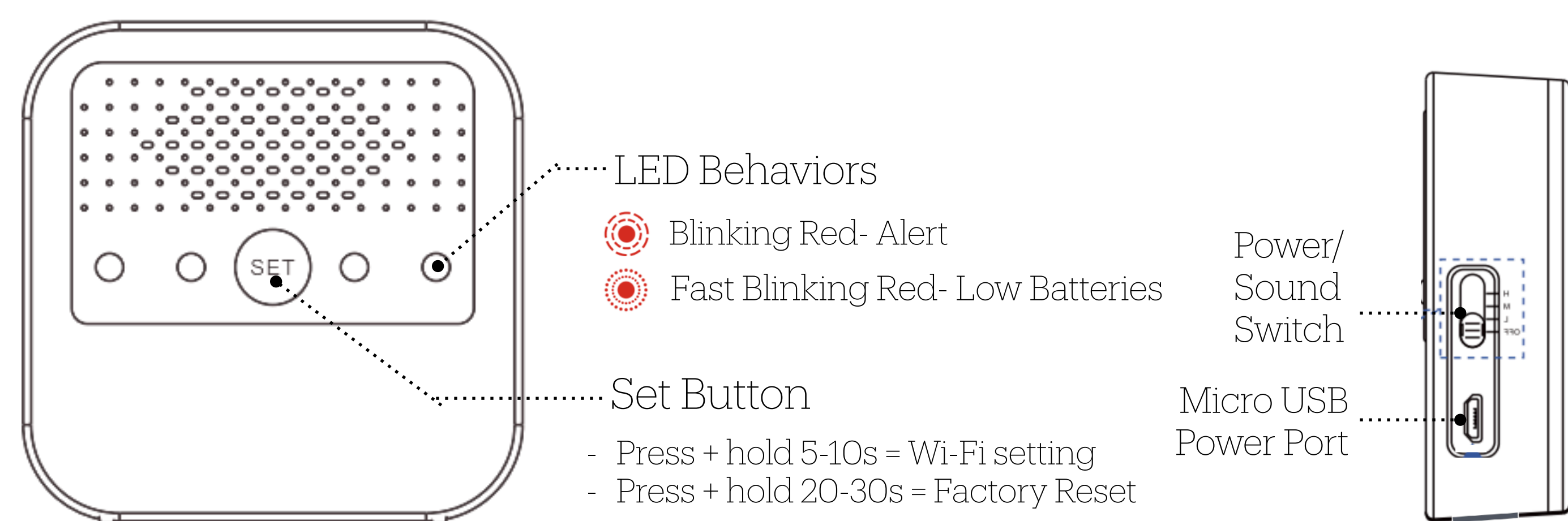

The **Remote Alert Units** have been preconfigured with your facility's Wi-Fi information and will automatically connect within range.

Check that the Remote Siren has backup batteries installed, and then plug both units into provided AC adapters.

**When a lifeguard enters the water:**

- The Siren will sound immediately. Use the slide switch on its side to set volume
- After a short delay the Speaker will chime and announce "Alert! A lifeguard has entered the water and may need assistance". The message will repeat.

**When the lifeguard exits the water, the Siren will silence itself and the Speaker will stop after it finishes the message.**

**Note:** If the Speaker becomes disconnected from Wi-Fi, **ONLY** the Speaker will sound. To silence the alert press the 'SET' button.

# Using WAVE Wearables:

## Tracker

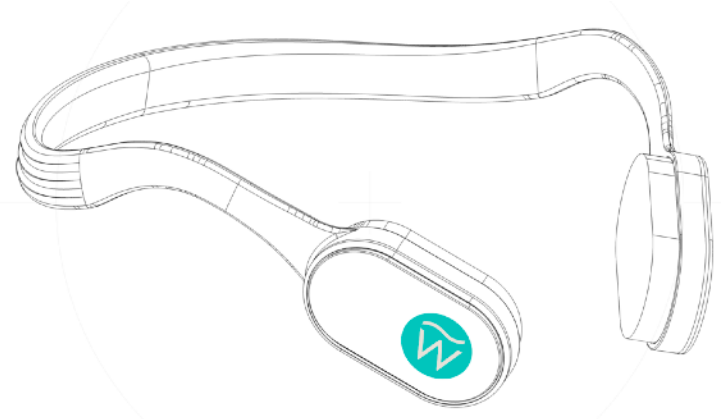

## Goggle Clips

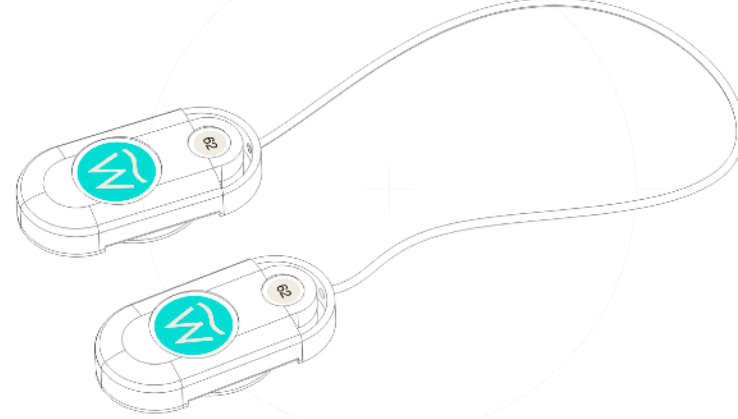

- No charging required
- Automatically activate when moved
- Must be worn as directed
- Do not allow to be removed from WAVE- monitored areas

## Staff Bracelet

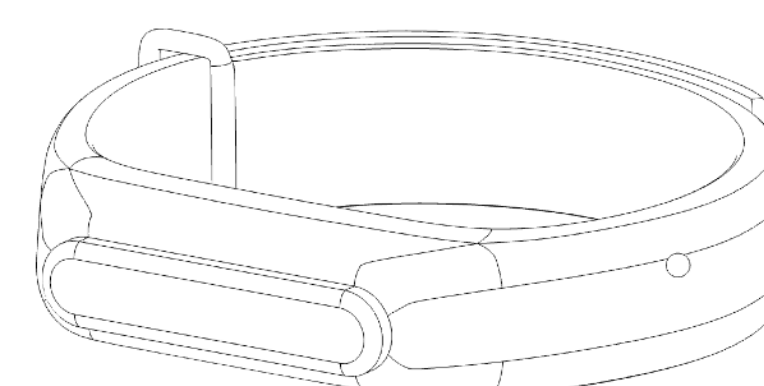

- Fully charge before using
- Do not allow to be removed from WAVE- monitored areas
- Dry completely before charging

## Lifeguard Tag

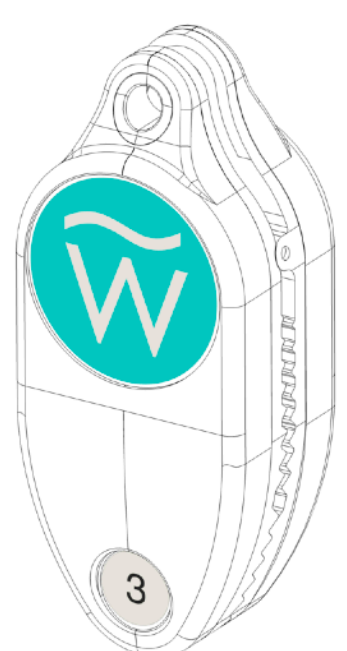

- No charging required
- Auto-activates when moved
- Must be worn as directed
- Do not allow to be removed from WAVE- monitored areas

**Tag must fully submerge when guard enters water**

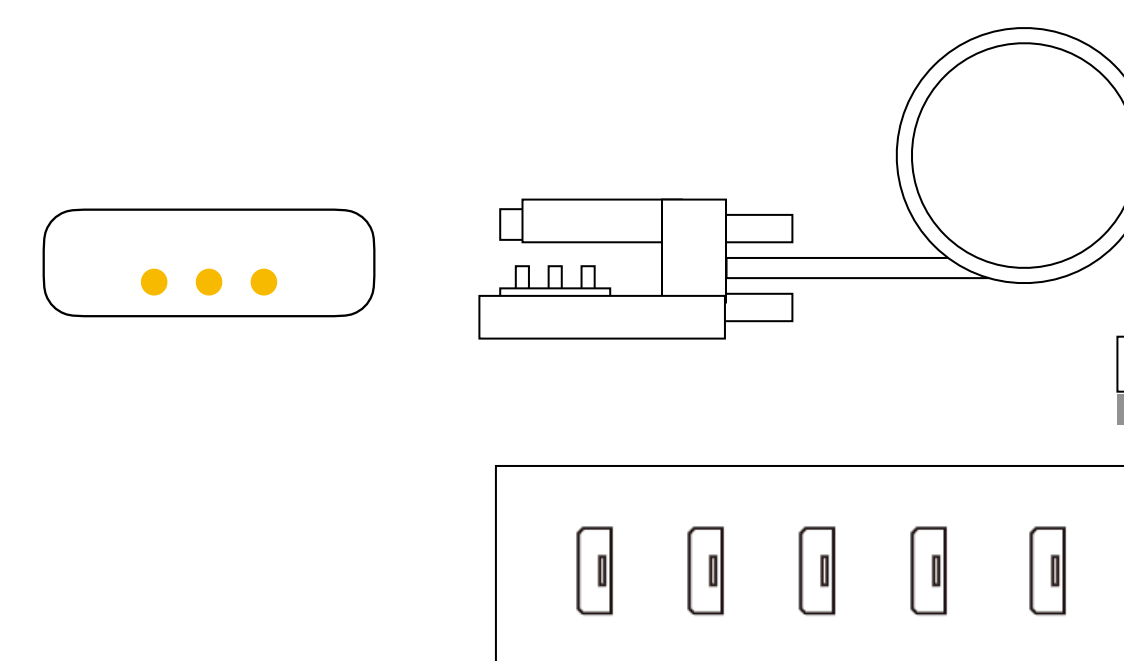
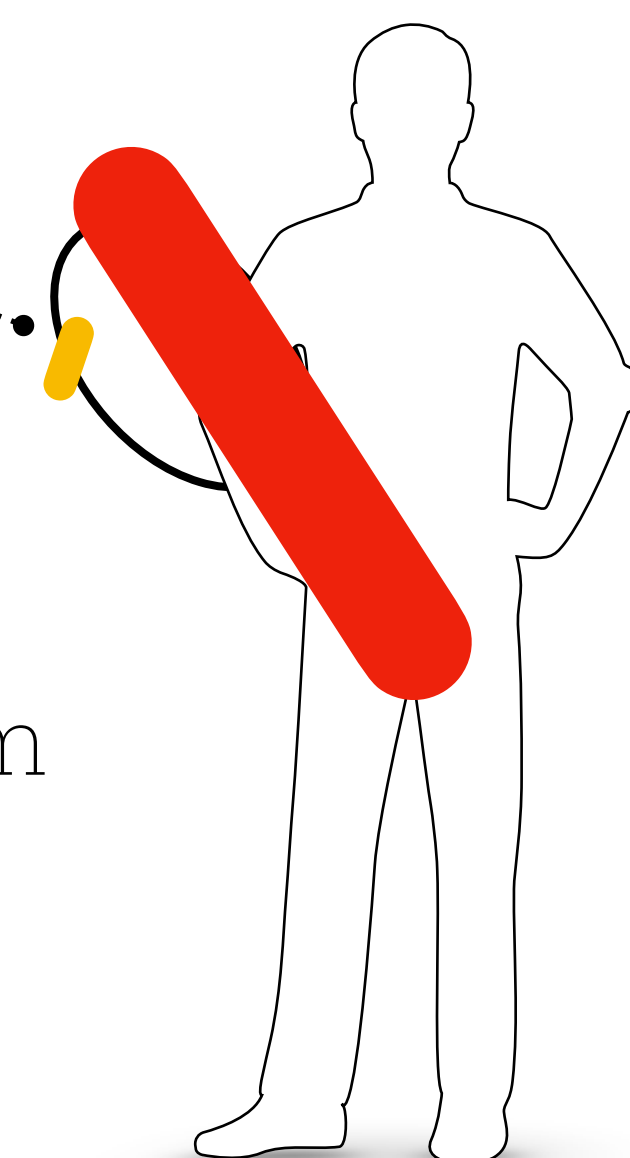

**To Charge Staff Bracelet:**

- (1) Align charging pads on back of plastic tag with Charging Clip pins
- (2) Connect Charging Clip cable to Multi-USB Charger
- (3) Charging is complete when tag LED turns blue

## ■ Accessing Hub Management Page.

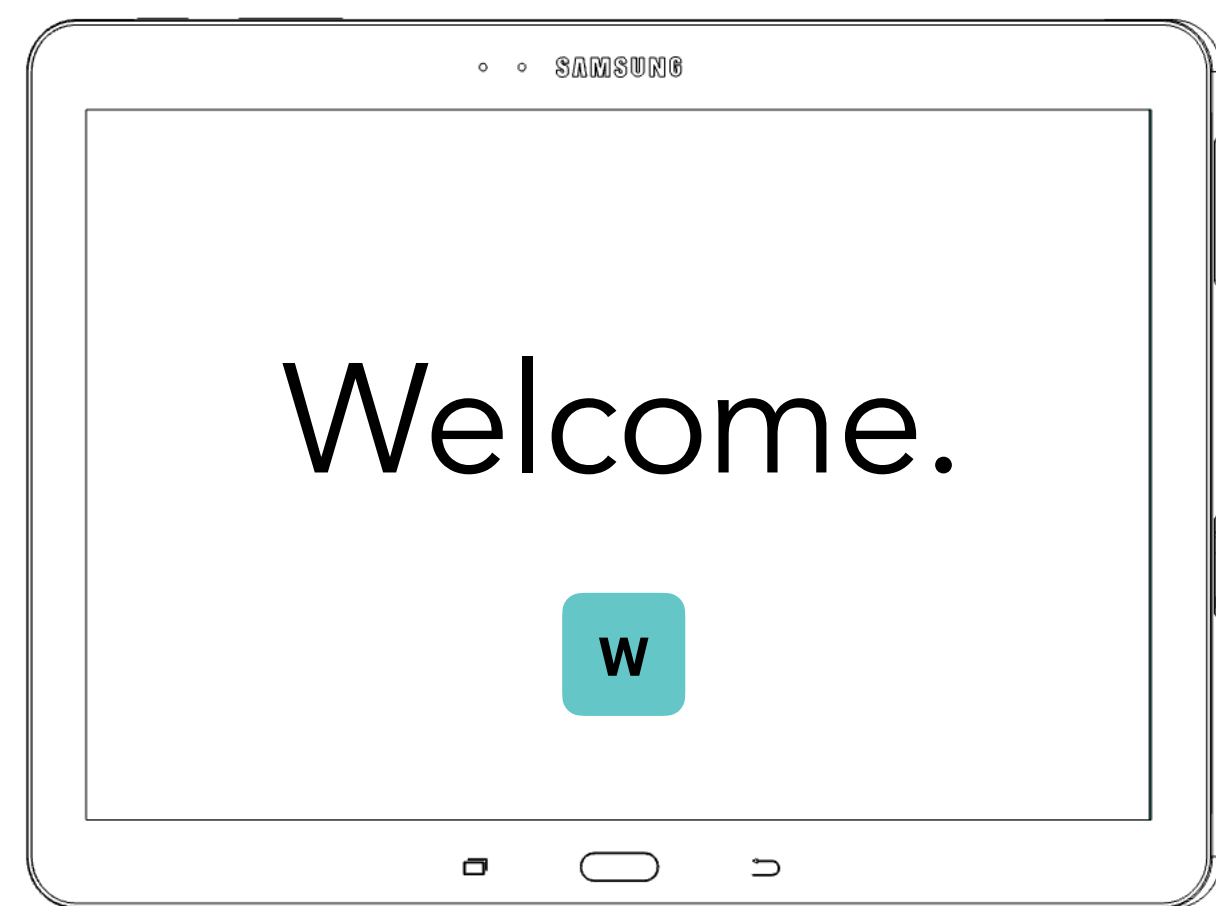

WAVE app on Tablet home screen

Write down URL found on back of Hub for future reference:

If your system includes a dedicated **Control Tablet**, it will be preconfigured to access management of your system. Open the WAVE app found on the home screen to monitor the status of your system and to set preferences.

If your system does not include a Control Tablet, you may use another device such as a phone, tablet, laptop or PC connected to the network. Enter the URL found on the back of the Hub into the device's browser. The Hub Management Page should appear.

If you are having problems accessing the page please contact us at [support@saferwithWAVE.com](mailto:support@saferwithWAVE.com).

## ■ Testing your system before use.

It is recommended to first test your proposed location for mounting the Hub and Monitors prior to permanently installing them. This can be done by having one person up on a ladder with the Hub and connected Monitor powered on. A tall tripod may also be used.

Have a second person walk around the swim area with Lifeguard Tags and/or Swimmer Wearables. Have each helper pause for ~10 seconds at locations furthest away from the Monitor and/or where obstructions may block line-of-site to the Monitor.

If your system does not alert, the location is likely suitable for installation. If alerts occur consider possible alternative locations or speak to WAVE Support about deploying additional Monitors.

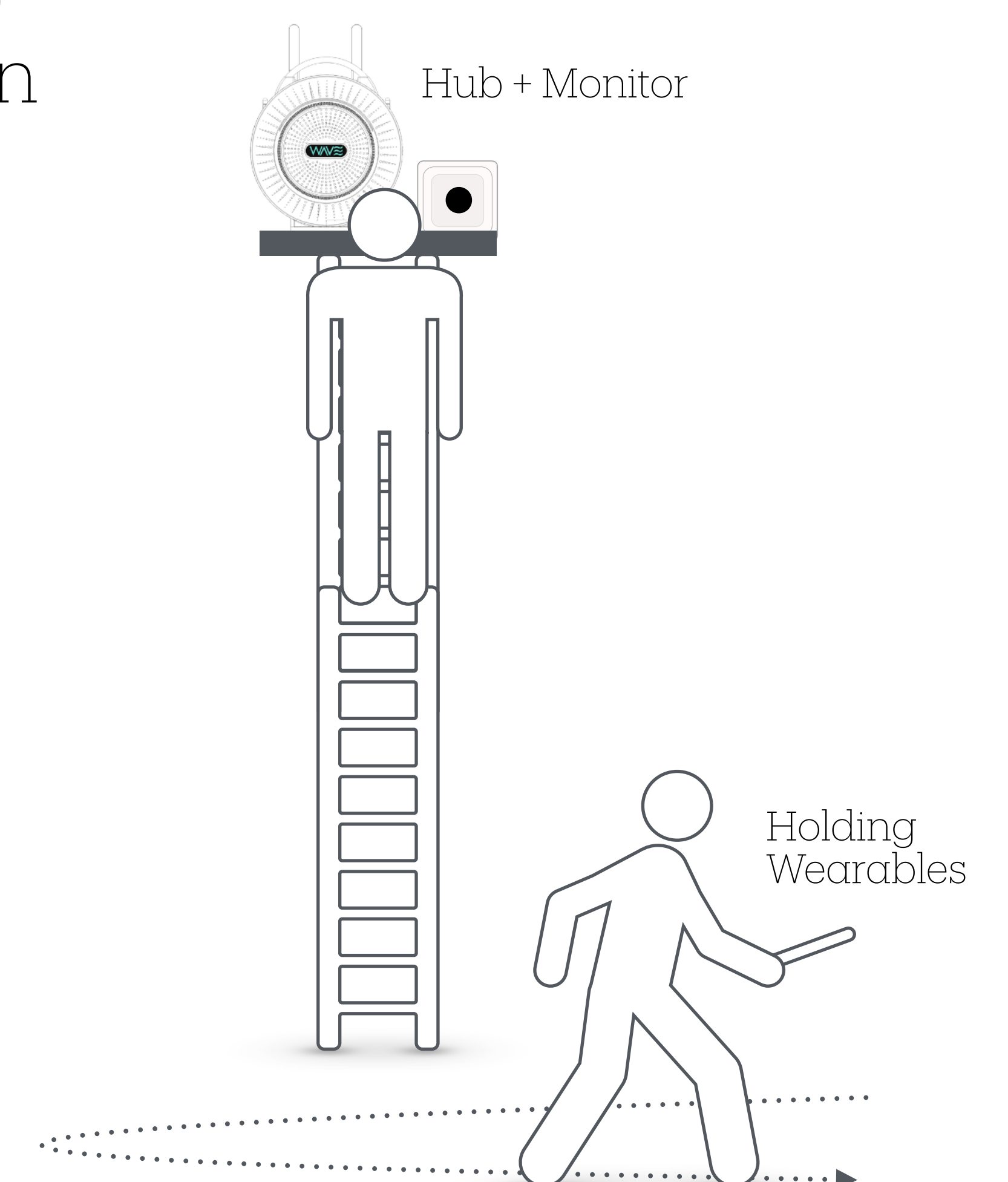

Important: Please read the WAVE NEW USER GUIDE available at [saferwithWAVE.com/user-resources](https://saferwithWAVE.com/user-resources) (password required)



# Questions?

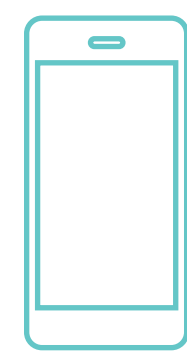

1 203 429 4636 during normal business hours

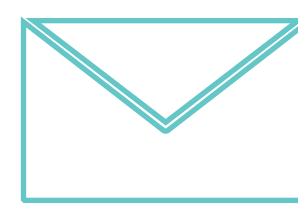

[support@saferwithWAVE.com](mailto:support@saferwithWAVE.com) 24/7/365



[saferwithWAVE.com/contact-us](https://saferwithWAVE.com/contact-us) 24/7/365



Read detailed NEW USER GUIDE at  
[saferwithWAVE.com/user-resources](https://saferwithWAVE.com/user-resources)

[ Password Required ]